

REGULAR CALLED MEETING BOARD OF DIRECTORS

Boardroom

August 15, 2023

5:30 p.m.

AGENDA

1. Call to Order Mayor Scott Byrd
2. Invocation
3. Approval of Board Minutes from August 1, 2023 – Mayor Byrd
4. Second Reading of Five Mill Tax – Gary Brinkley
5. Consideration of Approval for MOU with AR Dept of Health – Gary Brinkley/Stuart Tapson
6. Consideration of ANRC Loan for Sewer Project – Gary Brinkley/David Green
7. Ordinance to Rezone 313 S. 10th – DeAnna Graves
8. Acceptance of Planning Commissioner Resignation – Gary Brinkley
9. City Manager's Report – Gary Brinkley
10. Routine Business – Mayor Byrd
11. Adjournment – Mayor Byrd

Regular Meeting: Citizens speaking to the Board of Directors shall have a speaking time limit of **10 minutes**. The Board of Directors may ask follow up questions which may extend the time limit.

Open Session Forum: Speaking time limit is **5 minutes** and speaker may not yield his or her time to another speaker.

**REGULAR CALLED MEETING
BOARD OF DIRECTORS**

Board Room

August 1, 2023

5:30 P.M.

MEMBERS:

Taylor Chaney, *Ward 1 Director (absent)*
Chris Porter, *Ward 2 Director*
Keith Crews, *Ward 3 Director*
Reo Cummings, *Ward 4 Director*
Jason Jones, *Ward 5 Director*
Roland Gosey, *Assistant Mayor*
Scott Byrd, *Mayor*

OTHERS:

Gary Brinkley, *City Manager*
Samantha Roybal, *City Clerk*

CALL TO ORDER

The Mayor called the meeting to order at 5:30 p.m.

INVOCATION

Director Crews

APPROVAL OF BOARD MINUTES FROM JULY 18, 2023

A motion was made by Assistant Mayor Gosey seconded by Director Cummings to approve the minutes from the July 18, 2023, Board Meeting.

The motion passed on a roll call vote and the vote was as follows:

Taylor Chaney	"Absent"	Roland Gosey	"Aye"
Chris Porter	"Aye"	Jason Jones	"Aye"
Reo Cummings	"Aye"	Mayor Byrd	"Aye"
Keith Crews	"Aye"		

INTRODUCTION MS. HALLE POSEY, NEW SPECIAL EVENTS MANAGER

Mr. Brinkley introduced the new special event manager Halle Posey.

AIRPORT OPPORTUNITY FOR CONSIDERATION

Mr. Brinkley and Airport Manager Michael Sellers presented the Board with new Arkansas Dept. of Aeronautics (ADA) grant opportunities. The ADA grants would be for a new 4-Bay Hanger on the southern end of the airport and the accompanying taxiway work. The request is for a 90/10 for the above-ground work in the amount of \$500,000.000 and an 80/20 grant for all work below the surface in the amount of \$120,000.00 with the city's out-of-pocket expense would be in \$79,000.00.

A motion was made by Director Jones, seconded by Director Porter directing the City Manager to apply for both ADA grants, and if awarded the grant will be reflected in the 2024 airport budget.

The motion passed on a roll call vote and the vote was as follows:

Taylor Chaney	“Absent”	Roland Gosey	“Aye”
Chris Porter	“Aye”	Jason Jones	“Aye”
Reo Cummings	“Aye”	Mayor Byrd	“Aye”
Keith Crews	“Aye”		

CLARK COUNTY ARKANSAS MUSEUM LEASE

Mr. Brinkley presented the Board with documentation showing where the Clark County Historical Association had divested the museum from their portfolio and a new entity, Clark County Arkansas Museum Inc. had been created to manage the museum. It was an amicable separation as the new entity was a 501 (c) 3 which allowed for tax deductible donation. This change required a termination of the current lease with the Historical Assoc. and new lease with the Museum Inc. group effective August 1, 2023.

A motion was made by Director Porter, seconded by Director Crews approving the updated lease agreement with the Clark County Arkansas Museum, Inc.

The motion passed on a roll call vote and the vote was as follows:

Taylor Chaney	“Absent”	Roland Gosey	“Aye”
Chris Porter	“Aye”	Jason Jones	“Aye”
Reo Cummings	“Aye”	Mayor Byrd	“Aye”
Keith Crews	“Aye”		

FIRST READING OF ORDINANCE ASSESSING A FIVE MILL TAX

Mr. Brinkley presented the annual millage rate ordinance and requested the Board place the Ordinance on its first reading and following that, place it on its second reading, title only at the next scheduled Board meeting. Millage rate remains at 5 mills.

A motion was made by Director Crews, seconded by Assistant Mayor Gosey to place the Ordinance on its first reading.

The motion passed on a roll call vote and the vote was as follows:

Taylor Chaney	“Absent”	Roland Gosey	“Aye”
Chris Porter	“Aye”	Jason Jones	“Aye”
Reo Cummings	“Aye”	Mayor Byrd	“Aye”
Keith Crews	“Aye”		

The Mayor called for the Clerk to read the Ordinance in its entirety.

The Clerk read the Ordinance.

The Mayor called for a motion to place the Ordinance on its second reading, title only, at the next scheduled Board meeting.

A motion was made by Director Crews, seconded by Director Cummings to place the Ordinance on its second reading, title only at the next Board meeting.

The motion passed on a roll call vote and the vote was as follows:

Taylor Chaney	“Absent”	Roland Gosey	“Aye”
Chris Porter	“Aye”	Jason Jones	“Aye”
Reo Cummings	“Aye”	Mayor Byrd	“Aye”
Keith Crews	“Aye”		

CITY MANAGER’S REPORT

August 1, 2023

- Yielded time to Mayor to recognize Ms. Shacresha Wilson as the Arkansas GFOA Financial Officer of the Year for 2023.
- Water Dept staff has begun the relocation of water lines on S. 26th and Red Hill Road. These are the 2 projects that are being done in-house. All other work will be done by third-party contractors.
- The Street Dept. was able to get the school zone crosswalks painted for the new school year.
- My thanks to the City Department Heads with whom I met last week to go over the 2023 accomplishments and looking at 2024 goals. It is my pleasure to serve with so many professional men and women who work tirelessly to deliver quality services at frugal cost.
- We have reached terms with Hostess on the waste water pretreatment agreement. Documents to follow.
- The 10th Street Bridge is nearing completion. The contractor had to let the south headwall dry before proceeding as it was an extensive pour. They will be back to pour the north headwall this week and hopefully have the street open by the end of next week.

Dates to Remember:

- End of Summer Blowout in Feaster Park, August 12th from 5 pm to 9pm. Fireworks show at dusk.
- Both Universities and Public Schools start mid-August, be aware of all our new drivers in town.
- Board Retreat on August 26th from 9:00 am - 2:00 pm. It will be in the Alumni Room at OBU this year
- Acknowledged Ms. Samantha Roybal for the great service to the city as tonight is her last night as an employee of the city. She has accepted another position with a new corporation in town.

Taylor Chaney, Ward 1 – Absent.

Chris Porter, Ward 2 – Congratulations to Samantha, and Shacresha and stated how much he appreciates the way the Arkadelphia Board does business.

Keith Crews, Ward 3 – Nothing.

Reo Cummings, Ward 4 – Congratulations to Samantha and Shacresha. He would like Arkadelphia to be taken care of their property appearance before the new school starts.

Jason Jones, Ward 5 – Echoed the same sentiments and inquired about the pardon of our progress signs. He also wanted to know the status of the replacement of the lights on I-30.

Roland Gosey, Assistant Mayor – He thanked Shacresha, and Samantha and welcomed our new Special Events Manager. He also is thankful for the diversity of ages and representation among the city employees.

Scott Byrd, Mayor – He mentioned that the City Manager evaluation will occur at the next board meeting. He thanked Shacresha, Samantha and welcomed Halle Posey.

ADJOURNMENT

There being no further business to discuss, Director Jones made the motion, seconded by Director Cummings to adjourn. **The motion passed unanimously, and the meeting adjourned at 6:14 p.m.**

Scott Byrd, Mayor

Samantha Roybal, City Clerk

ADDITIONAL ATTENDEES

City Board of Directors Meeting

August 1, 2023

Page 5 of 5

Lisa Speer

John Knight

Tara Rollins

Michael Sellers

Jason Jackson

Lewis A. Shepherd Jr.

DRAFT



Memorandum

To: Arkadelphia Board of Directors
CC: Ed McCorkle, City Attorney
From: Gary Brinkley, City Manager 
Date: August 7, 2023
Re: Ordinance for Five Mill Tax 2023

Following the second reading, staff recommends putting the ordinance on its third reading, title only at the next meeting.

THIS IS NOT A NEW TAX

Thank you.

ORDINANCE O-23-_____

AN ORDINANCE ASSESSING A FIVE MILL TAX AGAINST THE REAL AND PERSONAL PROPERTY WITHIN THE CORPORATE LIMITS OF THE CITY OF ARKADELPHIA, ARKANSAS, FOR THE TAXABLE YEAR 2023 COLLECTIBLE IN 2024 AND FOR OTHER PURPOSES

BE IT ORDAINED BY THE CITY BOARD OF DIRECTORS OF THE CITY OF ARKADELPHIA, ARKANSAS:

Section 1. That a tax of five (5) mills on the dollar is hereby levied by the City Board of Directors of the City of Arkadelphia, Arkansas on all the real and personal property within the corporate limits of the City of Arkadelphia, for the taxable year 2023, collectible in 2024.

Section 2. That a certified copy of this ordinance be delivered by the City Clerk to the County Clerk of Clark County, Arkansas to be certified to the Quorum Court.

PASSED ON THE _____ DAY OF _____, 2023.

APPROVED:

Scott Byrd, Mayor

ATTEST:

Samantha Roybal, City Clerk



Memorandum

To: Arkadelphia Board of Directors
CC: Ed McCorkle, City Attorney
From: Gary Brinkley, City Manager
Date: August 3, 2023
Re: Memorandum of Agreement with Arkansas Dept of Health
Emergency Faculty for Administration of Medical Countermeasures



Attached for your review and consideration, please find a Memorandum of Agreement with the Arkansas Dept. of Health for the use of the Recreation Center should an emergency be declared and the facility be needed for the administration of medical countermeasures.

The agreement was reviewed by Attorney McCorkle.

Should you approve, we will address the contact information and reset the mileage estimations on page 14.

It is presented to you for consideration.

Thank you.



Arkansas Department of Health

4815 West Markham Street • Little Rock, Arkansas 72205-3867 • Telephone (501) 661-2000
Governor Sarah Huckabee Sanders
Renee Mallory RN, BSN, Secretary of Health
Jennifer Dillaha, MD, Director

**MEMORANDUM OF AGREEMENT
BETWEEN
ARKANSAS DEPARTMENT OF HEALTH [ADH]
AND
ARKADELPHIA RECREATION CENTER**

I. PURPOSE: EMERGENCY FACILITY USE FOR ADMINISTRATION OF MEDICAL COUNTERMEASURES.

The Arkansas Department of Health (hereafter referred to as **ADH**) and **ARKADELPHIA RECREATION CENTER** (hereafter referred to as the **Facility**) hereby enter into this Memorandum of Agreement (hereafter **MOA**) for the purpose of effectively responding to acts of biological and chemical terrorism and other public health emergencies. The Centers for Disease Control and Prevention (CDC) has stockpiled sustainable repositories of lifesaving medical countermeasures as needed to respond to an act of terrorism, pandemic, natural disaster, or public health emergency in the Strategic National Stockpile (SNS) Program at CDC. The Arkansas Department of Health has developed plans for the receipt, distribution, and dispensing/administering medical countermeasures. Those plans are combined in what shall be referred to as the Arkansas Strategic National Stockpile Plan. This Agreement will augment those plans for rapid deployment of medical countermeasures.

II. SCOPE OF SERVICES:

A. The Facility agrees:

1. To designate a 24-hour point of contact and alternate point of contact for the emergency utilization of medical countermeasures (MCM) and provide contact information to the ADH Preparedness and Emergency Response Branch, Strategic National Stockpile (ADH/SNS) Program, and Local Health Unit (LHU) at the time of

agreement on this MOA and notify the ADH/SNS Program and LHU of any changes in point of contact personnel within 48 hours.

2. To not charge individuals for medications or administration of that have been provided through this agreement, except as permitted by the State of Arkansas or by CDC.
3. To participate in dispensing/vaccination and training/education opportunities as requested by ADH.

B. The Arkansas Department of Health (ADH) Agrees:

1. To provide suitable staff and/or qualified volunteers and material to accomplish a mass dispensing/vaccination campaign to a large-scale public health event.
2. To provide mass prophylaxis dispensing/vaccination specific training/education opportunities to identified staff of the Facility.
3. To provide pre-event planning and technical assistance, including but not limited to supply lists, POD layouts, fact sheets, dispensing algorithms, etc.
4. To provide coordination as outlined in the County MCM Plan to the Facility to the best of their ability.
5. To make arrangements to collect any unused medical countermeasures as well as copies of all medical documentation.

C. It Is Mutually Agreed That:

1. The confidentiality of patients and patient information will be maintained as written and enforced by the Health Insurance Portability and Accountability Act (HIPAA).
2. This memorandum will go into effect only at the request and direction of the ADH.
3. The Facility would be considered a **Public POD** in that the physical facility would be utilized to dispense medications/administer vaccinations to the “general public,” identified staff, family members, patients, contacts, and specific groups outlined in the Facility’s Mass Prophylaxis Dispensing Site Plan as a component of the County MCM Plan.
4. It is understood that the Facility’s participation is completely voluntary and may not be available/utilized at the time of the event. If so, the Facility would not be

considered a POD, and their staff and/or specific groups would be required to attend a Public POD operated by ADH and not receive any preferential treatment.

III. Definitions

1. **Arkansas Department of Health (ADH)** - the State's public health agency and Emergency Support Function (ESF) # 8 lead agency.
2. **Arkansas SNS Plan** - a plan developed by the Arkansas Department of Health to receive, distribute, and dispense/administer the SNS, as Managed by the Centers for Disease Control and Prevention (CDC). This plan is updated annually with the assistance from partners identified as having a role in the AR SNS Plan.
3. **County SNS Plan** - a plan developed by the county health department, Arkansas Department of Health to dispense/administer medical countermeasures, as identified in the Arkansas Strategic National Stockpile plan. This plan is updated annually with the assistance from partners identified as having a role in the AR SNS Plan.
4. **Medical Countermeasure (MCM)** - includes those drugs, biological products, and devices that are intended to prevent or lessen the onset or duration of disease.
5. **Point of Dispensing (POD)** - a location where pharmaceuticals and other medications are distributed to end users; these facilities may range from small clinics to large operations with multiple staging and operation areas; these facilities may also support a range of methods of distributing drugs and medications to the patients.
6. **Public POD** - a POD that would dispense medications to the “general public” and to identified staff, family members, patients, contacts, and specific groups outlined in the Facility’s Mass Prophylaxis Dispensing Site Plan as a component of the County MCM Plan.
7. **Facility** - the business/organization willing to become a POD.
8. **Strategic National Stockpile (SNS)** - CDC's Strategic National Stockpile (SNS) has large quantities of medicine and medical supplies to protect the American public if there is a public health emergency (terrorist attack, flu outbreak, earthquake, etc.)

severe enough to cause local supplies to run out. Once federal and local authorities agree that the SNS is needed, medicines will be delivered to any state in the U.S. within 12 hours. Each state has plans to receive and distribute SNS medicine and medical supplies to local communities as quickly as possible.

IV. Terms and Conditions

1. **Effective Dates** - This MOA shall be effective when all parties have signed and will continue indefinitely, unless terminated according to Section IV, Terms and Conditions, Paragraph 2, Termination.
2. **Termination** - This agreement will be reviewed annually. Subject to the provisions contained below, this MOA may be terminated by either party providing sixty (60) days advance written notice of termination. Furthermore, in the event of budgetary reasons the ADH can no longer support this MOA, it shall terminate immediately upon written notification to the Facility.
3. **Amendment** - Any changes to this MOA, which are mutually agreed upon between ADH and the Facility, shall be incorporated in a written amendment to this MOA and will not become effective until the amendment is signed by both parties.
4. **Nondisclosure** - To the extent permitted by law, the parties agree that neither will disclose the location of SNS material or the nature of this effort except as is necessary to fulfill its mission and statutory and regulatory responsibilities.
5. **Liability** - Neither party shall be liable for any claims, demands, expenses, liabilities, and losses (including reasonable attorney's fees) which may arise out of any acts or failures to act by the other party, its employee, or agents in connection with the performance of services pursuant to this MOA.
6. **Non-Discrimination** - No person shall be excluded from participation in, be denied the benefits of, or be subjected to discrimination in relation to any activities carried out under this MOA on the grounds of race, disability, color, sex, religion, age, health status, or national origin.
7. **Evaluation of MOA** - Appropriate staff of the Facility and the ADH will review this MOA annually to evaluate this MOA based on the responsibilities for each party listed under section II, Scope of Services, of this Agreement.

8. **Governing Law** - This MOA shall be construed and enforced in accordance with appropriate federal laws and the laws of the State of Arkansas, specifically the Arkansas State Claims Commission laws.
9. **Licenses** - The parties agree that during the term of this MOA, each party shall maintain its respective federal and state licenses, certifications, and accreditations required for the provision of services herein.
10. **Expenses** - Each party shall bear and be responsible solely for its own costs and expenses necessary to comply with this MOA.
11. **Severability** - Should a court of competent jurisdiction rule any portion of this agreement invalid, null, or void, that fact shall not affect or invalidate any other portion or section of the agreement, and all remaining portions and sections of the agreement remain in full force and effect.

V. Signatures

ARKANSAS DEPARTMENT OF HEALTH

4815 West Markham Street, Slot 61
Little Rock, Arkansas 72205-3876
501-661-2000
www.healthy.arkansas.gov

ARKADELPHIA RECREATION CENTER

2555 Twin River Dr.
Arkadelphia, AR 71923

Tyler Sorrells
Arkansas Department of Health
State Strategic National Stockpile
(SNS) Coordinator
Cell: 501-607-9597

Signing Authority for Facility

Signatory Name (printed):

Position/Title:

Phone:

Signature:

Signature:

Date:

Date:

County of Operations: Clark

POD Pull-Out Plan: Primary Site

Clark County Vaccination/Dispensing Site

TABLE OF CONTENTS

Address:	1
GPS Coordinates:.....	1
Points of Contact:.....	2
Figure 1: Aerial Photo/Map of Facility.....	2
Figure 2: Site Floor Plan/Clinic Flow Plan.....	3
Figure 3: Site Floor Plan for Rapid Dispensing.....	4
Figure 4: Aerial Photo of Facility Showing Traffic Flow & Triage Location.....	5
Figure 5: Staff & Volunteer Staging Area	6
Figure 6: Traffic Control/Parking Officer Locations.....	7
Figure 7: Facility Evacuation Routes.....	8
Site Specific Security Plan: Arkadelphia Recreation Center.....	9
Figure 8: Security Officer Locations	10
POD Standards Checklist.....	11
Facility Assessment Information	11
Facility Accessibility Element	12
HVAC/Refrigeration Element	13
Security Element.....	14
Infrastructure Element	16
Signature Page: Arkadelphia Recreation Center POD Pull-Out Plan.....	17
Record of Changes.....	18

Address:

Arkadelphia Recreation Center
2555 Twin Rivers Dr.
Arkadelphia, AR 71923

GPS Coordinates:

LAT - 34°07'36.76"N : LONG - 93°04'41.97"W

Points of Contact:

Primary

Stuart Tapson, Arkadelphia Parks and Recreation Director

Cell:

Office:

Secondary

???

Cell:

Office:

Figure 1: Aerial Photo/Map of Facility

Arkadelphia Recreation Center
2555 Twin Rivers Dr.
Arkadelphia, AR 71923



LEGEND	
	Arkadelphia Rec Center

Figure 2: Site Floor Plan/Clinic Flow Plan

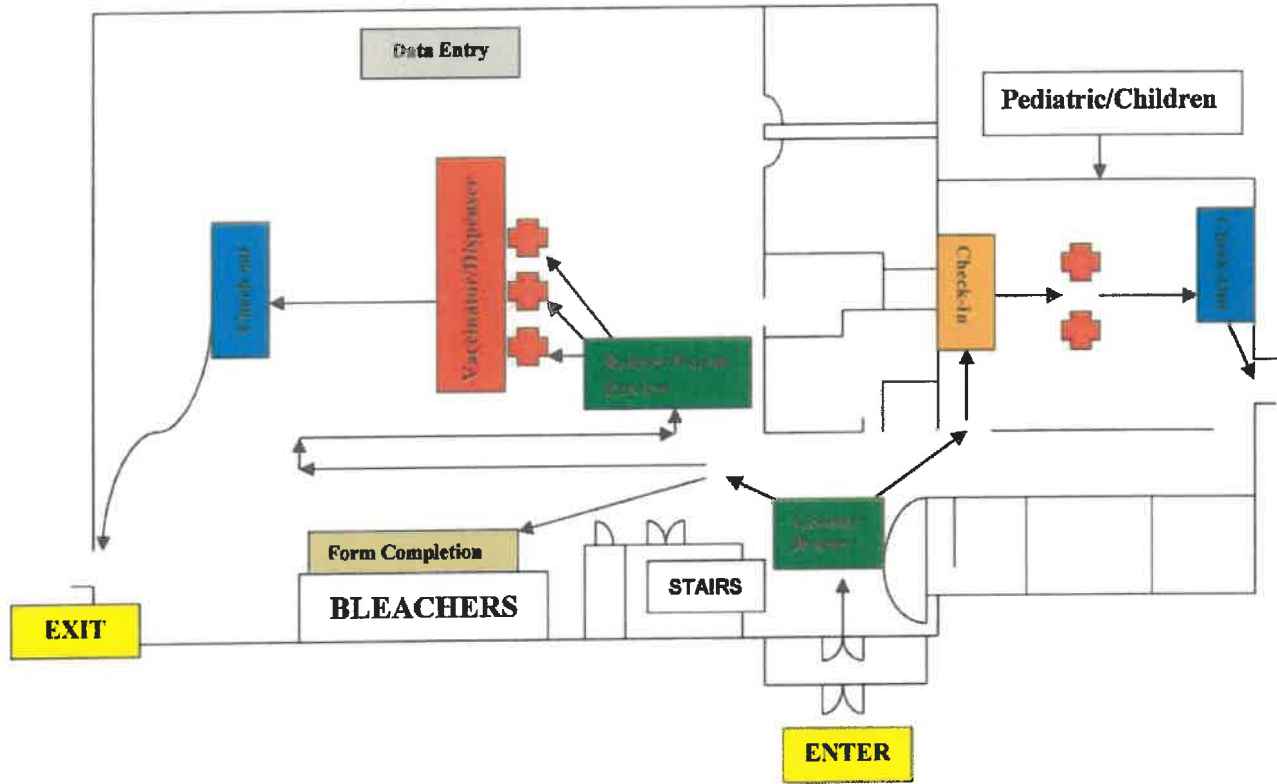

Figure 3: Site Floor Plan for Rapid Dispensing

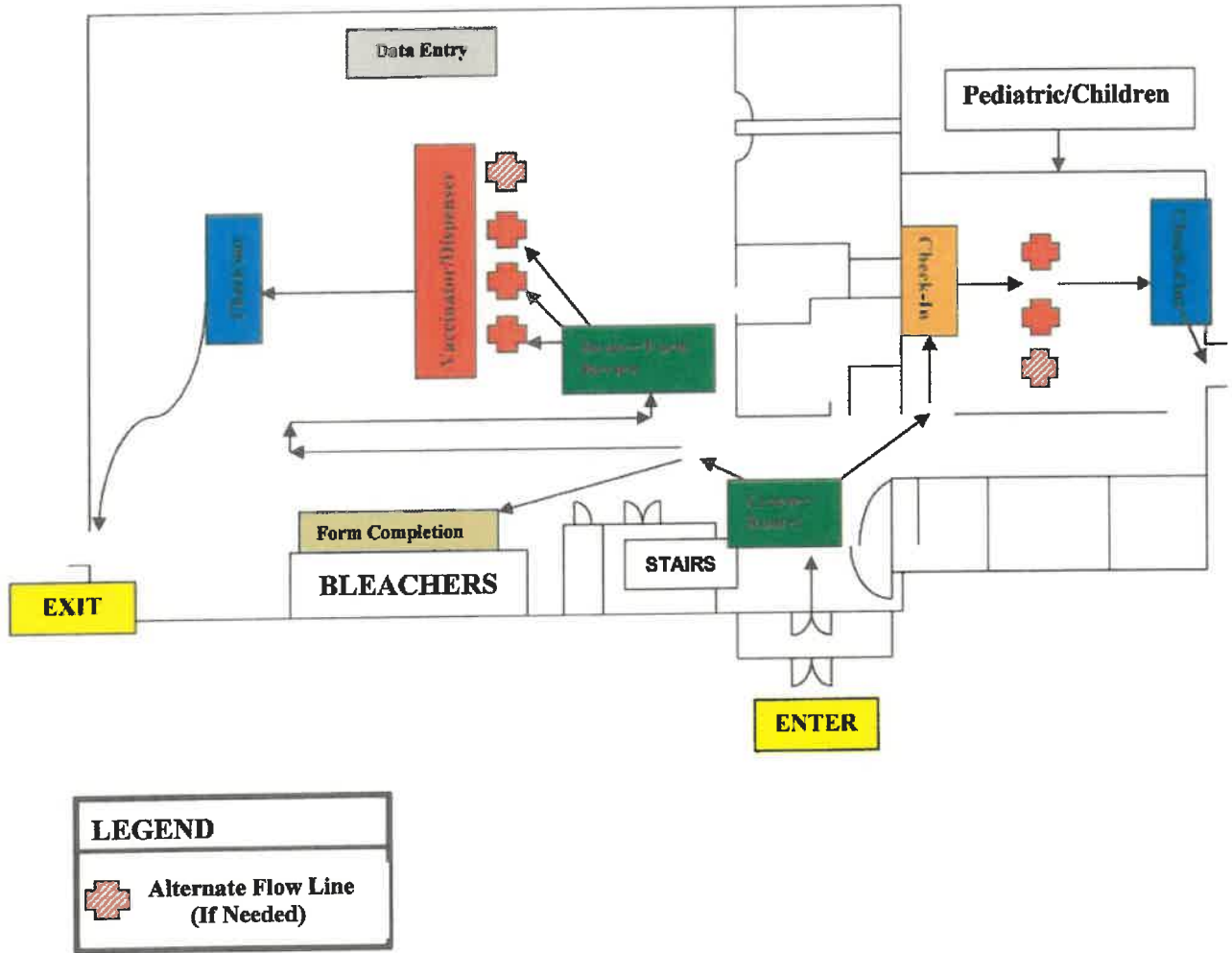

Figure 4: Aerial Photo of Facility Showing Traffic Flow & Triage Location







LEGEND	
	Staff/Volunteer Entrance
	Staff/Volunteer Exit
	Patient Entrance
	Patient Exit
	Initial Triage Area

Figure 5: Staff & Volunteer Staging Area



LEGEND	
	Clinical Staff/Volunteer Staging

Figure 6: Traffic Control/Parking Officer Locations

Figure 6 provides an aerial view of the locations needing traffic control/parking officers.



LEGEND

- Traffic Control
- ▲ Parking

Figure 7: Facility Evacuation Routes

Figure 7 provides a diagram of the evacuation routes for clinical staff, volunteers, and patients from the POD location.

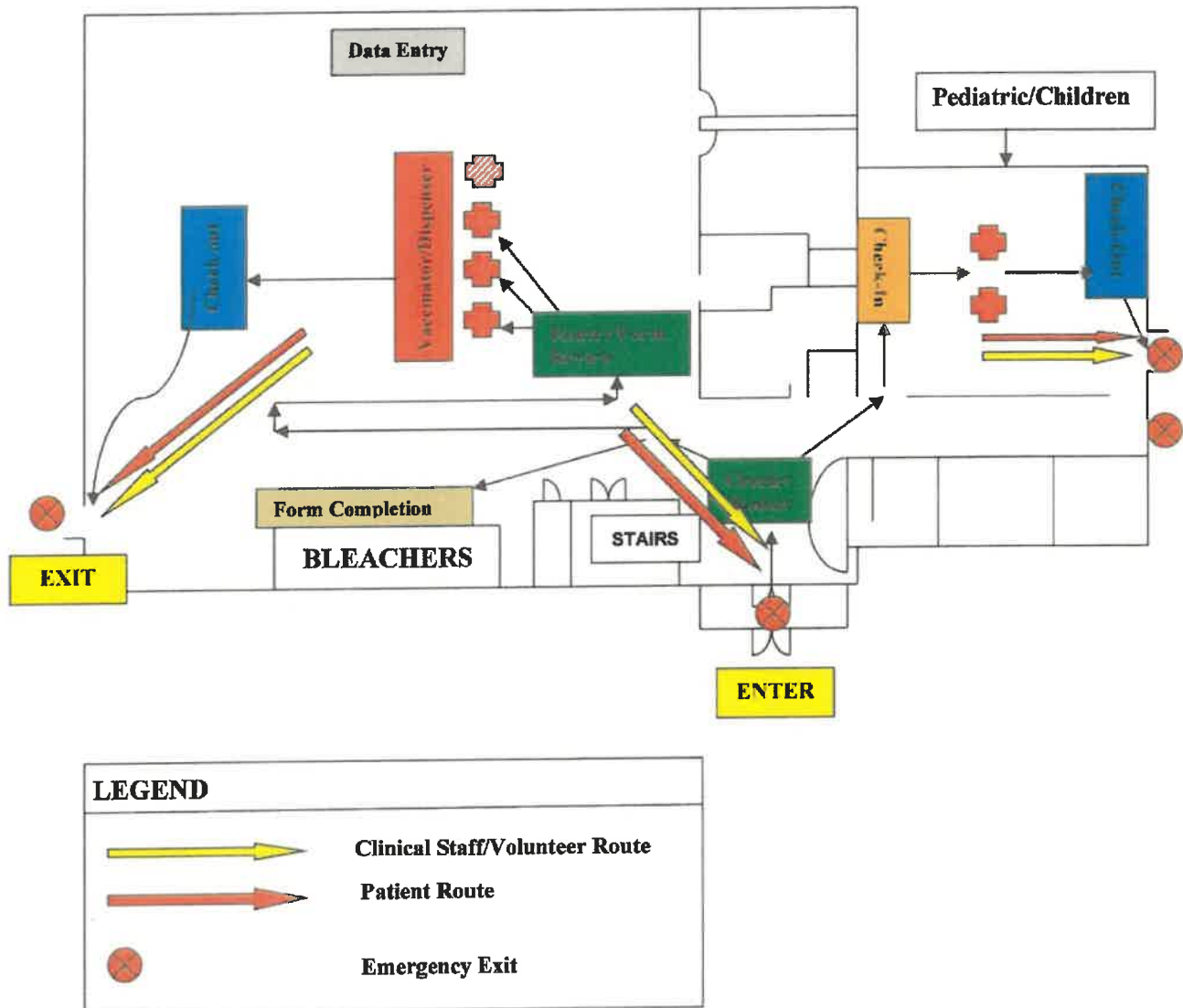

Site Specific Security Plan: Arkadelphia Recreation Center

Local Pod Security Coordinator

The local POD Security Coordinator will be responsible for the security of the local Point of Dispensing (POD) during activation by the Local Health Unit (LHU). The Security Coordinator will provide an overview of the total security operations.

Security Coordinator contact information: See MCM Plan Attachment 5 - Critical Contact List.

Implementation of Role

- Controlling crowds and traffic that might interfere with effective operations
- Protecting personnel, equipment, and material of the POD
- Coordination with federal, state, and local law enforcement agencies; state and local emergency management; and officially designated parties to identify potential threats and evaluate security requirements within the POD and surrounding area

POD Interior/Exterior Security

- Exterior security posts should be set up so they provide clear fields of view from one post to all adjacent posts. Rules of engagement should be given to the sentries.
- A command post and entry/exit area to the local POD site should be established.
- Shifts for the security and command post personnel must be established to provide coverage 24 hours per day and 7 days per week. The schedule should cover at least 72 hours in advance. A plan for meals, breaks, and relief for security personnel must be established. The local security command element must determine what specialized units and/or equipment they will need to provide the necessary security for the area when the SNS materials arrive.
- The local security command element should determine if additional physical barriers are needed. Consideration should be made for the barriers at the area entrance to slow the progress of vehicles into the area, and barriers may be needed to block other possible entrances to the area. The area should have one entrance and one exit to properly control traffic. Possible sources of barriers are the county road department, local law enforcement, Arkansas Highway and Transportation Department. Local heavy construction companies may also have these materials. The local security command element should check their areas during the hours of darkness to determine if additional lighting is needed. The same sources as cited above for the barrier materials would be potential sources for local security command elements to secure additional lighting if needed.
- A foot patrol of two security personnel, equipped with radios, should be considered. These patrols will move about freely within the POD and surrounding area to provide additional security and to monitor the site and security personnel on a frequent basis.

Plans for POD Security Communication

The LHU, in coordination with the local Office of Emergency Management Coordinator, will provide radios for the security personnel and gate guards at the POD site. The necessary radio channels will be secured and announced beforehand.

Figure 8: Security Officer Locations



LEGEND	
	Security Officer

Facility Accessibility Element	Answer
Is there access to more than one major road or highway from the POD facility, including access from any distribution or dispensing facilities? (Since trucks will likely be your primary means of transportation, the POD facilities should have clear unrestricted access to major highways and roadways.)	Yes
1 st street name	Twin Rivers Dr.
2 nd street name	N. 23 rd St.
Briefly describe the primary approach to the facility's entrance.	Exit off I-30, headed east onto Pine St. in Arkadelphia. Immediately take a left onto Professional Park Dr. Proceed to Twin Rivers Dr. and continue straight at the stop sign on 26 th St. to the Recreation Center.
Briefly describe the secondary approach to the facility's entrance.	Exit off I-30 headed east onto Pine St. in Arkadelphia. Proceed approximately 2 miles to N. 23 rd St. on the left. Follow N. 23 rd St. to the Recreation Center.
Can all approaches to the facility be blocked off if necessary?	Yes
Are roadways well-lit for nighttime operations per the jurisdiction having authority?	Yes
Is the facility accessible in all non-catastrophic weather conditions? (If POD accessibility is sometimes restricted due to weather, an alternate facility shall be identified.)	Yes
Can the facility be activated in the time necessary to achieve dispensing goals?	Yes
Can the facility be open for 24 hours per day for several days and maybe longer?	Yes
Number of square feet available in the largest area	5,000
If additional space is available in this POD, how (square feet) much is available?	1,000
Does the facility plan on using more than one floor for storage?	No
If yes, does the facility have suitable forklifts or elevators to move products between floors?	N/A
Does the facility have hard surface floors? (Hard surface floors such as concrete are required in the unloading area so containers, pallet jacks, and forklifts can be rolled through smoothly without hitting holes, rocks, or door jambs.)	Yes
Briefly describe flooring type.	Hardwood and concrete
Is the facility clean and free from infestation by insects, rodents, birds, or vermin, and chemical and mechanical hazards including any petroleum products?	Yes
Is the facility currently operating as a functioning establishment of some type?	Yes

Briefly describe what type of facility.	City recreation center
HVAC/Refrigeration Element	Answer
Does the facility offer temperature-controlled storage of medications between 68°F-77°F (20°C-25°C)?	Yes
Does the facility have functional and tested temperature monitoring/logging devices or service to monitor and record the temperature?	No
Is there a plan in place to provide emergency repairs to the environmental system to ensure temperatures do not exceed 104°F (40°C) for more than 24 hours?	No
What is the backup plan to maintain controlled room temperature if the environmental control system cannot be repaired within 24 hours?	Fans/Heaters
Does the facility offer refrigerated and frozen storage areas for biological agents such as vaccines?	Yes
Can the frozen storage area maintain a controlled temperature of -15°F to 5° F (-25°C to -15°C)?	Yes
Are calibrated thermometers with certificates of traceability and certification used to monitor the refrigerated and frozen storage areas a least twice a day with a log maintained of those temperature readings?	No
Is there a functional and tested alarm system to alert personnel if storage temperatures deviate outside of the specified range?	No
Is there a functional and tested notification system to contact personnel if temperatures deviate outside of the specified range?	No
Has the electrical power supply to the biological cold storage areas been protected? (This includes labeling the refrigeration/freezer outlets, fuses, circuit breakers, and power circuits with information that identifies the perishable nature of biological agents and the immediate actions to be taken in case of the interruption of power.)	No
Are the power circuits for the refrigeration/freezer storage areas on backup power?	No
What is the backup plan for ensuring vaccines are always stored at the proper temperature?	Coolers/Ice Packs/Thermometers

Security Element	Answer
Based on a local law enforcement security assessment, is the facility capable of securely receiving, storing, staging, and distributing medical materials? (If a law enforcement security assessment was accomplished, include the name, address, and phone number for the agency that completed the assessment as well as a point of contact at that agency.)	Yes
Are there any facilities nearby which might pose a security or safety threat (example: prisons, halfway houses, and chemical refineries)?	No
Is the facility located in a high crime area?	No
Is the Regional PHP Coordinator or local law enforcement aware of any problems with vehicular traffic congestion in the area that would affect the shipping and receiving of material?	No
What is the distance (in miles) to the nearest local law enforcement station?	1.2 miles
What is the name and address of the nearest local law enforcement station?	Clark County Sheriff's Office: 406 S. 5 th St, Arkadelphia, AR 71923
What is the distance (in miles) to the nearest fire station?	1.5 miles
What is the fire station name and address?	Arkadelphia Fire Department: 123 N 26 th St, Arkadelphia, AR 71923
What is the distance (in miles) to the nearest hospital?	3.5 miles
Does the hospital have an acute care facility?	Yes
What is the name and address of the hospital?	Baptist Health Medical Center: 3050 Twin Rivers Dr, Arkadelphia, AR 71923
Briefly describe security plans for transportation escort.	Clark County Sheriff's Office will escort MCM supplies as needed.
Security and vulnerability assessment of location and facility strengths/weaknesses	Open area, easily controlled, traffic easily controlled
Security sweep prior to facility use/occupancy by staff or product	Yes
Establishment of law enforcement officer posts.	Yes
Access control to locations within the facility.	Yes
Crowd control inside the facility	Yes
Specialized unit needs (canine, explosive ordnance disposal, tactical, traffic, etc.)	Yes
Additional physical barriers (necessity and/or identification of source)	Yes
Additional lighting (necessity and/or identification of source)	Yes
Staging area for personnel and vehicles.	Yes
Vehicular traffic control (ingress and egress)	Yes
Crowd control outside the facility	Yes

Access control to facility	Yes
Establish command center for law enforcement	Yes
Determine radio channels	Yes
Ensure communication and coordination between law enforcement organizations	Yes
Establish sufficient number of law enforcement officers	Yes
Evacuation plans	Yes
Briefly describe security plans for the dispensing site (and staging area, if applicable).	Officers will be used for traffic control and security as needed.
Is the entry to and exit from parking areas controlled by a guard?	Yes
Is the parking area adequate for expected population to be served?	Yes
Is this facility utilized as a drive-thru POD?	Yes
Is the lighting of the building grounds adequate as required by the law enforcement jurisdiction having authority?	Yes
If so, are the lights on all night, controlled by a timer, or manually controlled?	Timer
Are exterior light control switches accessible to unauthorized persons?	No
Does the interior have sufficient lighting to maintain a safe work place as required by the jurisdiction having authority?	Yes
Does a security barrier limit or control vehicle or pedestrian access to the facility?	Yes
Are there gates that can be closed and locked?	No
On the facility site, are there items such as bricks, stones, or wooden fences, which could be used as weapons or tools by intruders?	No
Are windows that could be used for entry protected with secondary closures as required by the jurisdiction having authority and based on a state or local law enforcement security assessment?	No
Does the facility have the capability to provide a locked area inside the building to store controlled substances?	Yes

Infrastructure Element	Answer
Is there adequate power with backup to operate essential POD functions?	Yes
If generator is offsite, will it be in place and operational in time to commence operations at the POD?	Yes
If the generator is offsite, provide the 24/7 contact information of the individual or agency responsible for installing the system	Tate Chanler, Clark County OEM
Are an adequate number of qualified individuals available to operate and monitor the backup generator(s) per OSHA and the jurisdiction having authority?	Yes
Is there a telephone system in the facility?	Yes
Describe the telephone system. Is it onsite or offsite? If it is onsite, is it operational?	Onsite/Operational
Are there AWIN or HAM Radios available or on site?	Mobile AWIN
Describe the radio system. Is it onsite or offsite? If it is onsite, is it operational? If it is not operational, provide 24/7 contact information for the individual or agency responsible for activating the system and the time required to active the system. If the system is offsite, provide the 24/7 contact information for the individual or agency responsible for installing and activating the system and the time required to complete the work.	Offsite/Mobile AWIN
Is there a public address system in the facility?	Yes
Describe the public address system. Is it onsite or offsite? If it is onsite, is it operational? If it is not operational, provide 24/7 contact information for the individual or agency responsible for activating the system and the time required to active the system. If the system is offsite, provide 24/7 contact information for the individual or agency responsible for installing and activating the system and the time required to complete the work.	Telephone intercom or portable PA
Are there one or more communications system used exclusively for security purposes available at the facility?	AWIN

Signature Page: Arkadelphia Recreation Center POD Pull-Out Plan

The signatories below concur with the POD review and the information gathered in this POD Pull-Out Plan.

Primary Facility Contact (24/7 with keys)

Name: Stuart Tapson
Title: Arkadelphia Parks and Recreation Director
Agency: City of Arkadelphia

Signature: _____

Date: _____

Secondary Facility Contact (24/7 with keys)

Name: *Alicia Nichols*
Title: *Facility Supervisor*
Agency: *Arkadelphia Parks & Rec*

Signature: _____

Date: _____

Regional PHP Coordinator

Name: Penny Welchel
Title: SW Region Public Health Preparedness Coordinator
Agency: Arkansas Department of Health

Signature: _____

Date: _____

Law Enforcement

Name: Jason Watson
Title: Clark County Sheriff
Agency: Clark County Sheriff's Department

Signature: _____

Date: _____

Record of Changes

Change(s)	Date	Person Making Change
Renumbered figures; added table of contents; updated facility POCs, LHU rep, and PHPC names; added record of changes table	6/12/2023	Penny Welchel



Memorandum

To: Arkadelphia Board of Directors
CC: Ed McCorkle, City Attorney
From: Gary Brinkley, City Manager
Date: August 10, 2023
Re: Resolution to Accept ANRC Funding for Sewer Project

A handwritten signature in blue ink, appearing to be 'Gary Brinkley', is written over the 'From:' line.

Attached please find a Resolution to accept a loan from the Arkansas Natural Resource Commission and for the city manager to execute the agreement.

The terms of the agreement are as follows:

1. Loan amount \$1,917,030
2. Term: 20 years
3. Combined annual rate per annum 1.75%
4. July 1, 2024, date the city has to decommit the funds
5. This offer terminates on August 18, 2023

Staff is working with the bonding agent, bond attorney and civil engineers to finalize the proposed \$10MM bond for the work on Pine Street and the bypass.

Should this loan in addition to the bond debt become a burden on the system, we will decommit to this offer. You will recall; the loan is to replace the 1969 built lift station and lines need of replacement.

Staff recommends you approve the Resolution and direct staff to present the entire financial package before incurring construction expenditures.

Thank you.

RESOLUTION NO. R-23-_____

A RESOLUTION DESIGNATING AND AUTHORIZING THE CITY MANAGER TO EXECUTE CERTAIN DOCUMENTS IN CONNECTION WITH THE CLEAN WATER STATE REVOLVING LOAN FUND ADMINISTERED BY THE ARKANSAS NATURAL RESOURCES COMMISSION

WHEREAS, the City of Arkadelphia, Arkansas owns and operates a sewer system (the “System”) in order to provide sanitary service to meet the needs of the City of Arkadelphia and its inhabitants; and

WHEREAS, the Board of Directors has determined that it is in the best interest of the City and its inhabitants to apply for loan assistance from the Arkansas Natural Resources Commission (the “ANRC”) under the Clean Water State Revolving Loan Fund Program (the “Program”), in order to make certain improvements;

- Replacement of certain high-pressure sanitary sewer lines
- Replacement of Ouachita Sewer Lift Station
- Other ancillary work to address these replacements

NOW, THEREFORE, BE IT RESOLVED BY THE BOARD OF DIRECTORS OF THE CITY OF ARKADELPHIA, ARKANSAS:

Section 1. The terms of the proposed loan to the City of Arkadelphia shall be: \$1,917,030 borrowed for 20 years at the combined rate of 1.75% per annum.

Section 2. That the City Manager as the Signatory Agent or the successor of said Agent, is hereby authorized and directed to execute the Acceptance of Loan Term document with the Arkansas Natural Resources Division as presented on July 7, 2023 correspondence.

PASSED AND APPROVED THIS 15th day of August, 2023.

Scott Byrd, Mayor

ATTEST:

City Clerk



Sarah Huckabee Sanders
Governor

ARKANSAS DEPARTMENT OF AGRICULTURE

1 Natural Resources Drive, Little Rock, AR 72205
agriculture.arkansas.gov
(501) 225-1598



Wes Ward
Secretary of Agriculture

July 7, 2023

Mr. David Green, Utility Manager
Arkadelphia Water Utilities
700 Clay Street
Arkadelphia, Arkansas 71923

RE: Approval of Financial Assistance

Mr. Green,

At its meeting on June 22, 2023, the Arkansas Natural Resources Commission approved your request for financial assistance in the form of a loan in the amount up to \$1,917,030 from the Clean Water State Revolving Loan Fund. These funds are to be used for the replacement of the Wastewater Ouachita Pump Station and Force Main as detailed in your funding application.

The Director will set the combined annual borrower rate and loan terms at the time of loan closing. The anticipated term for your funding is 20 years with a combined rate of 1.75% per annum. Your loan terms are contingent on full loan closing including first disbursement of funds on or before July 1, 2024. In the event this does not occur, the combined rate will be determined based on current available program rates at the time of closing.

If you accept the funding offer and would like to move forward with the proposed project, please sign and return the attached funding acceptance form. The included acceptance certification must be returned to Ryan Benefield by August 18, 2023, to accept the above-mentioned loan(s). If you fail to accept the proposed funding prior August 18, 2023, your financial assistance will be considered declined, and you will have to reapply for funding.

Sincerely,

Chris Colclasure
Director
Natural Resource Division

CC:dcj:ab

cc via email only: Matt Dunn, Consulting Engineer, Crist Engineers, Inc.



ARKANSAS DEPARTMENT OF AGRICULTURE



Sarah Huckabee Sanders
Governor

1 Natural Resources Drive, Little Rock, AR 72205
agriculture.arkansas.gov
(501) 225-1598

Wes Ward
Secretary of Agriculture

Acceptance of Loan Terms with Arkansas Natural Resources Division

By signing and returning this form the City of Arkadelphia is accepting the offer of financial assistance approved by the Arkansas Natural Resources Commission on June 22, 2023, and acknowledges the following:

1. To close on this financial assistance the borrower will raise revenue as needed to fully fund debt service, O & M, and depreciation reserve at 110% coverage and it is initially estimated that the following average increases in average water rates will be necessary. The final revenue increases will be determined at loan closing, but please anticipate an 51% increase.
2. The Director will set the combined annual borrower rate and loan terms at the time of loan closing. The anticipated term for the funding is 20 years with a combined rate of 1.75% per annum. The loan terms are contingent on full loan closing including first disbursement of funds on or before July 1, 2024. In the event this does not occur, the combined rate will be determined based on current available program lending rates. Determining if a loan has met all program requirements and is ready to close will be the sole discretion of the Director.
3. Prior to loan closing and acceptance of funds the Borrower may reject the financial assistance and the funds will be de-obligated.
4. The borrower understands that upon completion of the project any awarded financial assistance that is not utilized to complete the project approved in the application will be de-obligated and that any grant or principal forgiveness funds will be disbursed in a proportionate percentage to the approved loans.
5. The borrower understands that to receive this financial assistance they must comply with all State and Federal laws and program requirements.

Name of Borrower	Name and Title of Duly Authorized Representative	
Signature		Date

This acceptance must be received by August 18, 2023. Please return it to:

J. Ryan Benefield, P.E.
Deputy Director
Natural Resources Division
Arkansas Department of Agriculture

RESOLUTION NO. R-22-13

A RESOLUTION EXPRESSING THE WILLINGNESS OF THE CITY OF ARKADELPHIA, ARKANSAS TO UTILIZE DEPARTMENT OF AGRICULTURE FUNDS

WHEREAS, the Dept. of Agriculture is administration state grants using ARPA funds for water and wastewater projects, and;

WHEREAS, the Arkadelphia Water Utility has identified at least seven projects that meet the grant criteria and are worthy of submittal for consideration, and;

WHEREAS, grants would assist the betterment of the utility while leveraging utility resources.

NOW, THEREFORE, BE IT RESOLVED by the Board of Directors of the City of Arkadelphia, Arkansas:

SECTION I: The City of Arkadelphia Board of Directors does hereby acknowledge the submission of the following applications:

- a. AWU-Water Meter Replacement with AMI System - \$7,562,250
- b. Pine Street Water Main Relocations- ArDOT No.070439 - \$3,232,025
- c. Pine Street Sewer Main Relocations- ArDOT No. 070439 - \$3,015,859
- d. Ouachita Pump Station & Force Main - \$2,556,040
- e. AWU-Gum Spring Water System Improvements - \$605,650
- f. AWU- New Elevated Water Storage Tank Pressure Zone – \$7,376,920
- g. ArDOT Bypass Water line Relocation - \$4,714,121

SECTION II: Should the Arkadelphia Water Utility be fortunate enough to receive one or more of these grants, the city staff will present the award to the Board of Directors for confirmation

Passed on this 15th day of December, 2022.

Signed: 

Mayor Scott Byrd

ATTEST: 
(SEAL) _____
Samantha Roybal, City Clerk



Memorandum

To: Arkadelphia Board of Directors
CC: Ed McCorkle, City Attorney
From: Gary Brinkley, City Manager
Date: August 10, 2023
Re: Ordinance to Rezone 313 S. 10th

A handwritten signature in blue ink, appearing to be 'G. Brinkley', is written over the 'From:' line of the memorandum.

Attached for your review and approval please find the ordinance to rezone 313 S. 10th.

The Planning Commission met on August 10th and approved the zoning from Multi-Family Residential (R-3) to Office Commercial District (C-4).

We have also attached the Certification to the City Board of Directors regarding this recommendation.

Thank you.

ORDINANCE NO. 0-23-

AN ORDINANCE TO REZONE CERTAIN PROPERTY IN THE CITY OF ARKADELPHIA, ARKANSAS KNOWN AS 313 S. 10TH STREET AND MORE ACCURATELY DESCRIBED AS PART OF BLOCK FORTY-ONE (41) OF BROWNING SURVEY OF ARKADELPHIA, ARKANSAS AND PART OF LOT ONE (1), BLOCK EIGHTEEN (18) OF THE MADDOX ADDITION OF ARKADELPHIA, CLARK COUNTY, ARKANSAS; AMENDING THE ZONING MAP OF THE CITY OF ARKADELPHIA, ARKANSAS; AND FOR OTHER PURPOSES.

WHEREAS, Darren L. Ayres and Patricia M. Ayres wish to rezone property described below affecting the use of the property; and

WHEREAS, the Planning Commission held a public hearing on August 10, 2023 and voted to recommend that the Arkadelphia Board of Directors rezone property known as 313 S. 10th Street from the present Multi-Family Residential Use District (R-3) to Office Commercial District (C-4).

THEREFORE, BE IT ORDAINED BY THE BOARD OF DIRECTORS OF THE CITY OF ARKADELPHIA, ARKANSAS:

SECTION 1: That the following property, to wit:

A PARCEL OF LAND BEING A PART OF LOT 1 OF BLOCK 18 OF MADDOX ADDITION AND ALL OF LOTS 4, 5, 6 AND PART OF LOTS 1, 2, 3 OF BLOCK 41 OF BROWNING'S SURVEY IN THE CITY OF ARKADELPHIA, ARKANSAS AND BEING DESCRIBED AS FOLLOWS: BEGIN AT THE SOUTHEAST CORNER OF SAID LOT 6 OF BLOCK 41 OF BROWNING'S SURVEY, THE POINT OF BEGINNING; THENCE NORTH 02°32'13" EAST ALONG THE EAST LINE OF SAID BLOCK 41, A DISTANCE OF 105.00 FEET; THENCE NORTH 88°22'47" WEST, A DISTANCE OF 126.00 FEET TO THE EAST LINE OF LOT 1 BLOCK 18 OF MADDOX ADDITION; THENCE NORTH 88°22'47" WEST, A DISTANCE OF 25.50 FEET; THENCE SOUTH 02°32'13" WEST, A DISTANCE OF 109.00 FEET; THENCE SOUTH 88°22'47" EAST, A DISTANCE OF 25.50 FEET TO THE WEST LINE OF BROWNING'S SURVEY; THENCE NORTH 02°32'13" EAST A DISTANCE OF 4.00 FEET TO THE SOUTHWEST CORNER OF SAID LOT 4 OF BLOCK 41 OF BROWNING'S SURVEY; THENCE SOUTH 88°22'47" EAST, A DISTANCE OF 126.00 FEET TO THE POINT OF BEGINNING. CONTAINING 16,000 SQUARE FEET, MORE OR LESS.

Should be and is hereby rezoned from Multi-Family Residential Use District (R-3) to Office Commercial District (C-4) and the zoning map of the City of Arkadelphia, Arkansas is hereby amended to show said classification.

SECTION 2: Severability – If any section of this ordinance shall be declared unconstitutional or unlawful, only that section of the ordinance shall be affected and all other provisions of the ordinance shall remain in full force and effect.

SECTION 3: Any ordinance or parts of ordinances in conflict herewith are hereby repealed and this ordinance shall be in full force and effect from and after its passage and publication.

PASSED AND APPROVED this ____ day of _____ 2023.

APPROVED: _____
Scott Byrd, Mayor

ATTEST: _____
Acting City Clerk

CERTIFICATION TO THE CITY BOARD OF DIRECTORS

To: Board of Directors, City of Arkadelphia, Arkansas

From: Arkadelphia Planning Commission

Re: Consideration to rezone 313 S 10th Street

The following items are transmitted herewith:

1. Rezoning petition
2. Notice of public hearing
3. Rezoning ordinance

These items are those approved by the Arkadelphia Planning Commission.

The statutory requirements have been meet including:

- Notice of public hearing was given on July 23, 2023
- Public hearing was conducted on August 10, 2023
- Petition was approved by the Planning Commission on August 10, 2023.

The Arkadelphia Planning Commission recommends and requests the following action be taken by the Board of Directors:

Rezone the following property from Multi-Family Residential Use District (R-3) to Office Commercial District (C-4):

A PARCEL OF LAND BEING A PART OF LOT 1 OF BLOCK 18 OF MADDOX ADDITION AND ALL OF LOTS 4, 5, 6 AND PART OF LOTS 1, 2, 3 OF BLOCK 41 OF BROWNING'S SURVEY IN THE CITY OF ARKADELPHIA, ARKANSAS AND BEING DESCRIBED AS FOLLOWS: BEG AT THE SOUTEAST VORNER OF SAID LOT 6 OF BLOCK 41 OF BROWNING'S SURVEY, THE POINT OF BEGINNING; THENCE NORTH 02°32'13" EAST ALONG THE EAST LINE OF SAID BLOCK 41, A DISTANCE OF 105.00 FEET; THENCE NORTH 88°22'47" WEST, A DISTANCE OF 126.00 FEET TO THE EAST LINE OF LOT 1 BLOCK 18 OF MADDOX ADDITION; THENCE NORTH 88°22'47" WEST, A DISTANCE OF 25.50 FEET; THENCE SOUTH 02°32'13" WEST, A DISTANCE OF 109.00 FEET; THENCE SOUTH 88°22'47" EAST, A DISTANCE OF 25.50 FEET TO THE WEST LINE OF BROWNING'S SURVEY; THENCE NORTH 02°32'13" EAST A DISTANCE OF 4.00 FEET TO THE SOUTHWEST CORNER OF SAID LOT 4 OF BLOCK 41 OF BROWNING'S SURVEY; THENCE SOUTH 88°22'47" EAST, A DISTANCE OF 126.00 FEET TO THE POINT OF BEGINNING. CONTAINING 16,000 SQUARE FEET, MORE OR LESS.

Recommended for the following reasons:

Rezoning this property would align with the zoning of the abutting properties to the north & east and allow the Ayres some flexibility with the uses permitted. Office Commercial District (C-4) allows both commercial and residential use.

Granting the rezoning would extend the existing Office Commercial District (C-4) on the west side of 10th Street southward to the north side of Clay Street.

Signed by Planning Commission Chairman: WR Phelps

Date 8-10-2023



313 S 10th St

Rezone from R-3 to C-4

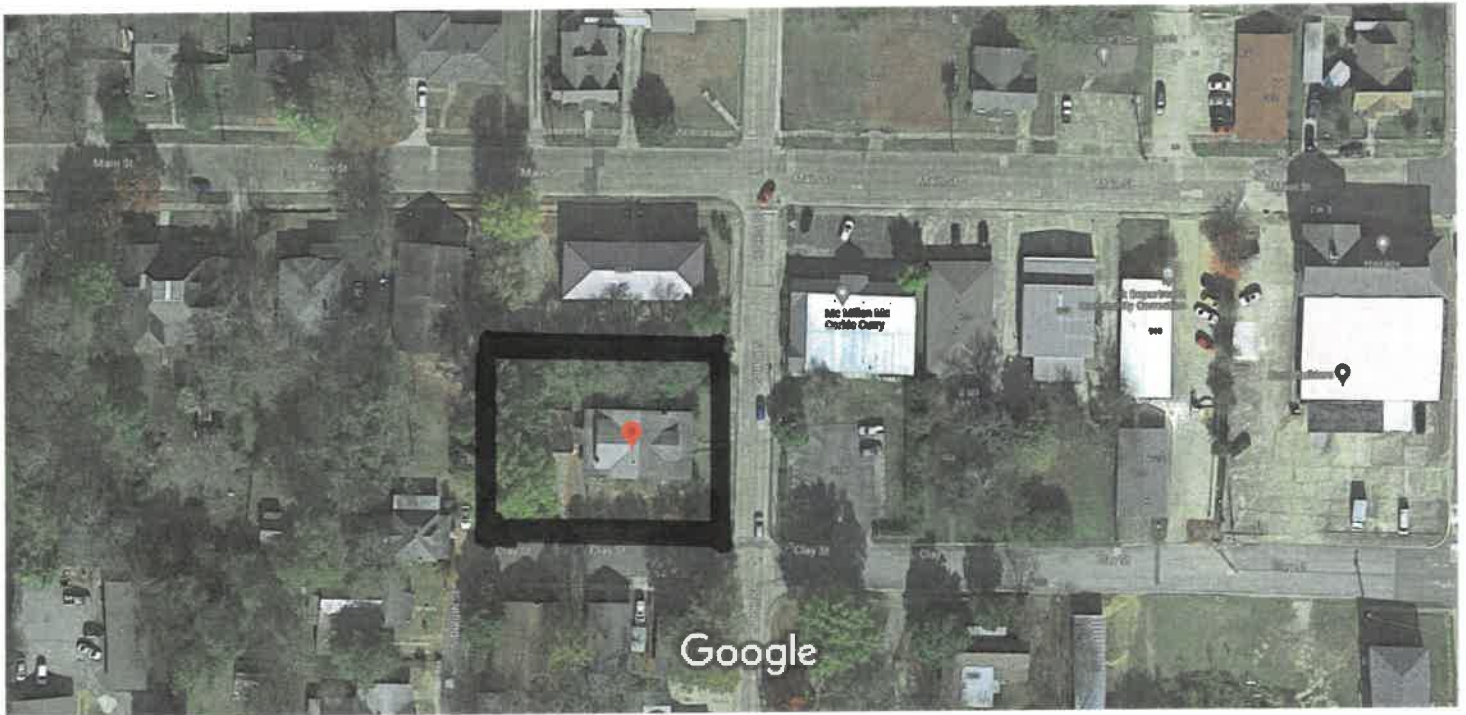

Imagery ©2023 Google, Imagery ©2023 Maxar Technologies, Map data ©2023 Google 50 ft



Memorandum

To: Arkadelphia Board of Directors
CC: Ed McCorkle, City Attorney
From: Gary Brinkley, City Manager 
Date: August 10, 2023
Re: Resignation of Planning Commission Member

Attached please find the resignation of Llewellyn E. Terry, Sr from the Planning Commission and Board of Adjustments.

Mr. Terry has served on this Board for over seven years.

Staff recommends you accept the resignation.

Thank you.

August 10, 2023

To: Deanna Graves, Building Department Manager
From: Llewellyn Terry, Planning Commission Member

This letter comes as a notice of resignation of my position as a Planning Commission member, effective August 10, 2023.

This has been a great experience and much learning has taken place for me. Thank you for the opportunity to serve our community in this capacity over the past seven years.

Sincerely,

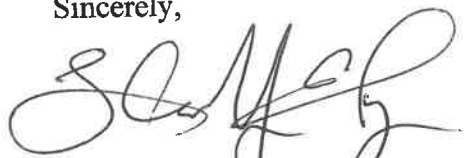
A handwritten signature in black ink, appearing to read "Llewellyn E. Terry, Sr.", written in a cursive style.

Llewellyn E. Terry, Sr.